

LCA 系列螺纹插装式单向阀

Screw-in cartridge check valve



LCA 是一种锥面密封型螺纹单向插装阀。

当单向阀油口A与B（反向单向阀则相反）的压差达到弹簧预紧力时，阀芯上升，阀口开启，油液可以从A流向B，反向则紧闭。

技术参数 technical specification

型号	LCA-4-		LCA-6-		
	31.5a-00	31.5a-02	31.5a-00	31.5b-00	F31.5b-00
流量 l/min	20	30	25	30	30
开启压力MPa	0.05	0.05	0.4	0.4	0.4
正反	正				反
工作压力MPa	31.5				
液压介质	矿物质液压油、磷酸脂液压油				
介质温度范围℃	-20~70				
介质粘度范围mm ² /s	2.8~320				

型号说明 model instruction

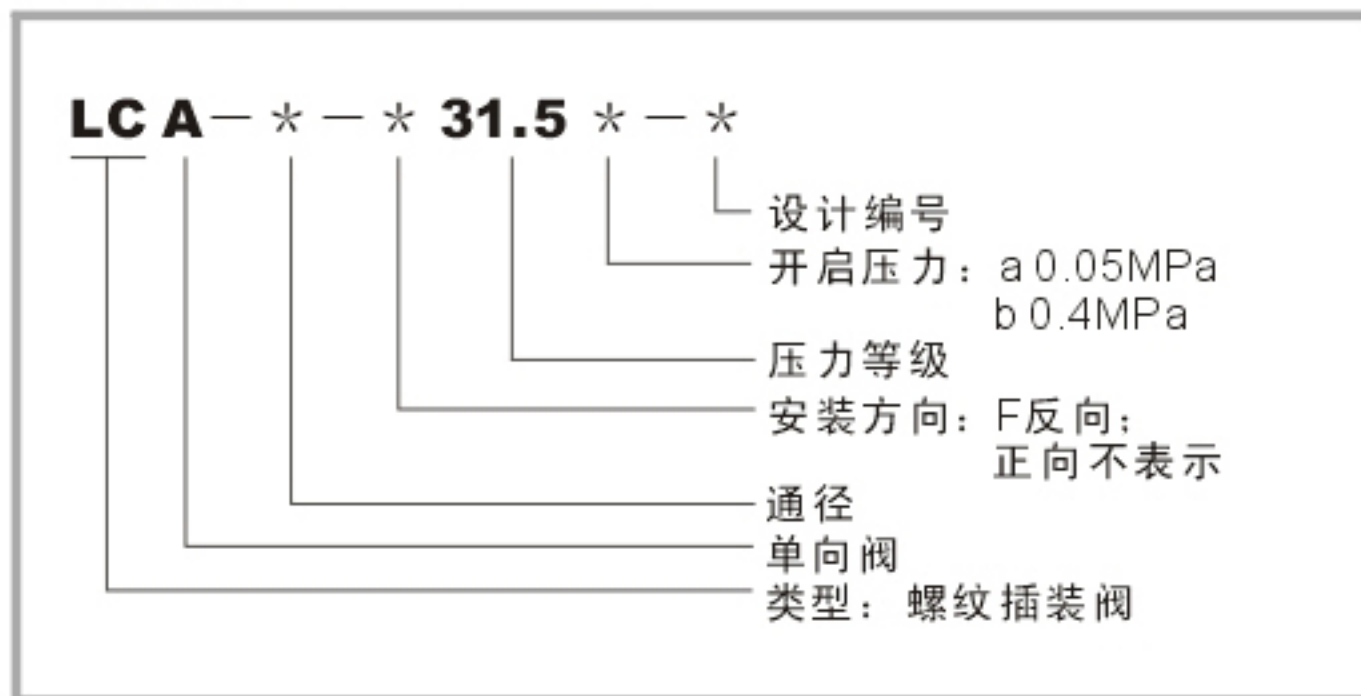

机能符号 code symbol

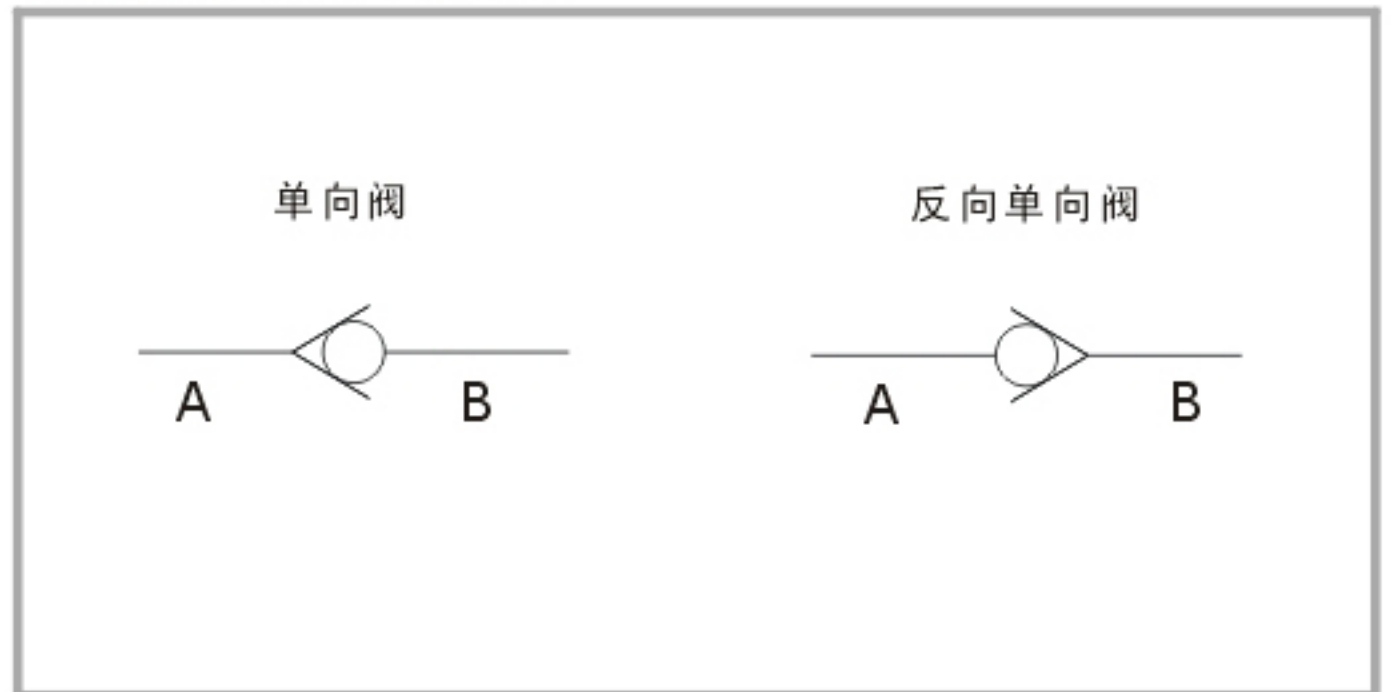

参考外形 external dimension

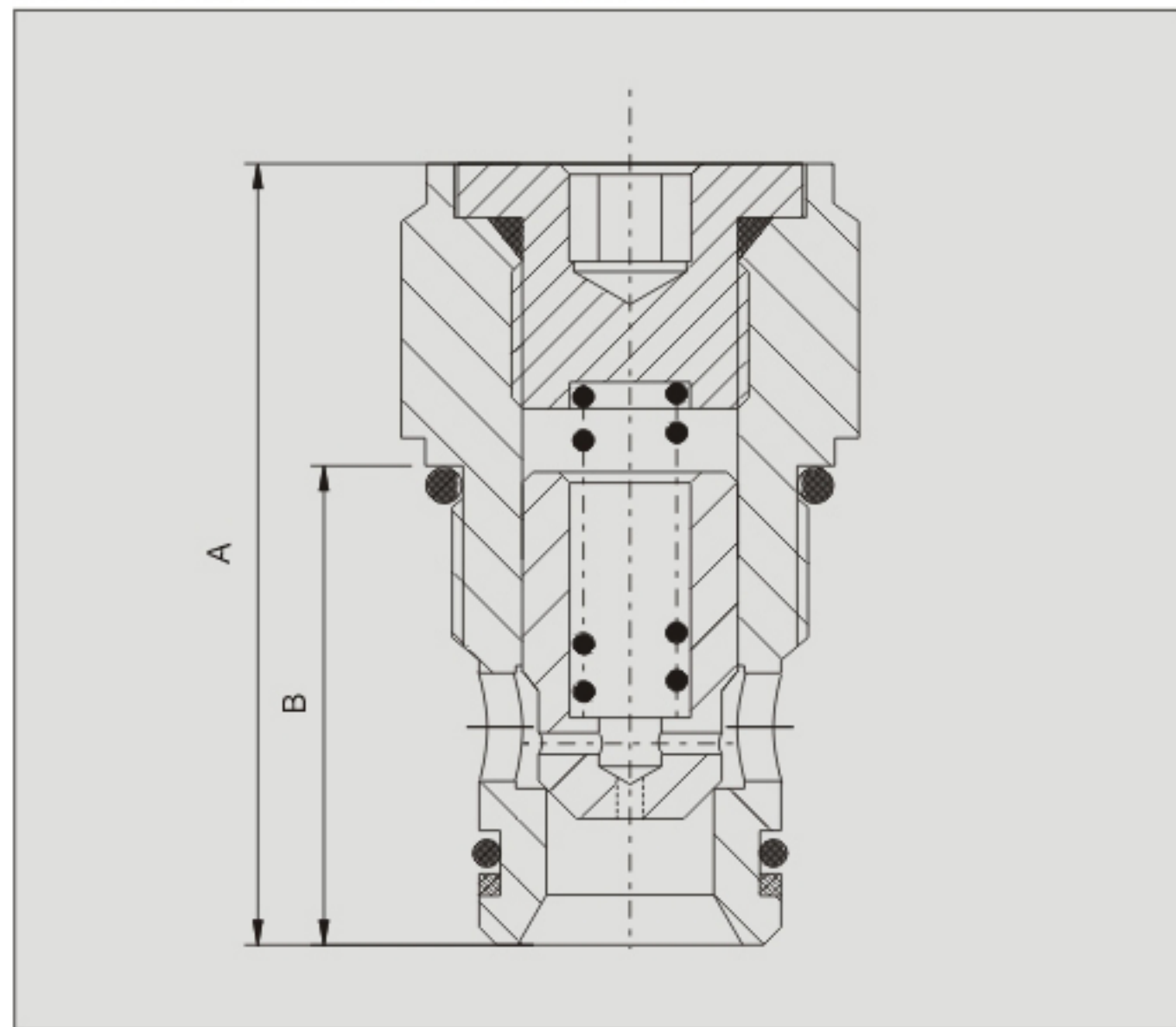

插件孔尺寸 hole size

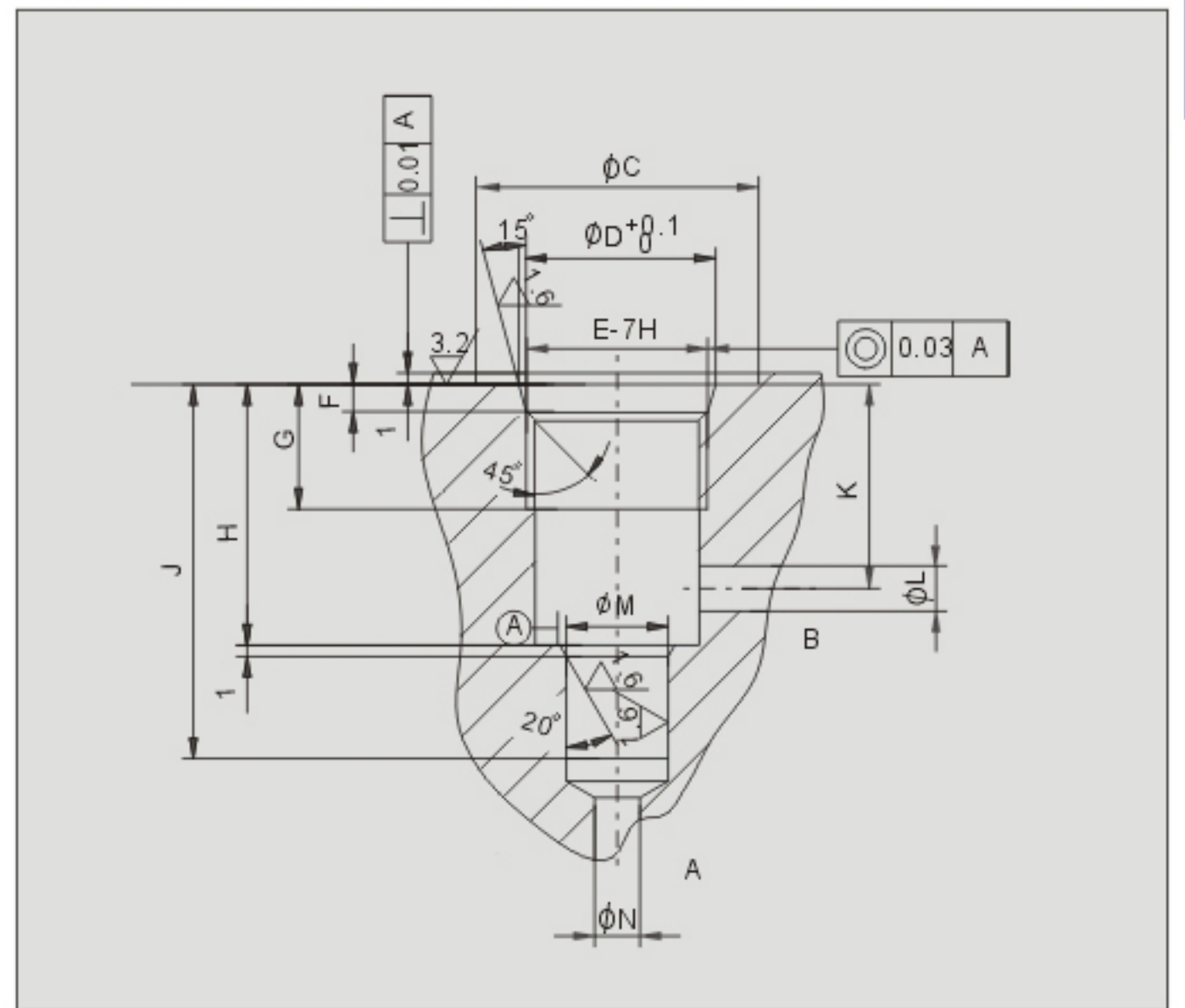

型号	A	B	C	D	E	F	G	H	J	K	L	M	N
LCA-4-31.5a-02	42.7	36	22	18.2	M16x1.5-7H	2.8	16	28	38	24	7	13H8	12
LCA-4-31.5a-00	32.5	26.5	23	19.8	M18x1.5-7H	2.4	12	17	25	13	6.5	15H8	6.5
LCA-6-31.5b-00	36.8	26.8	28	20.8	3/4-16UNF-2B	3	15	18	32	13	9	12.7H8	9
LCA-6-31.5b-04	47	27	27	21.8	M20x1.5-7H	2.4	15	19	27	15	8	16H8	12
LCA-6-F31.5b-00	36.8	26.8	28	20.8	3/4-16UNF-2B	3	15	18	32	13	9	12.7H8	9